

COLLECTOR / UNDERDRAIN DETAIL

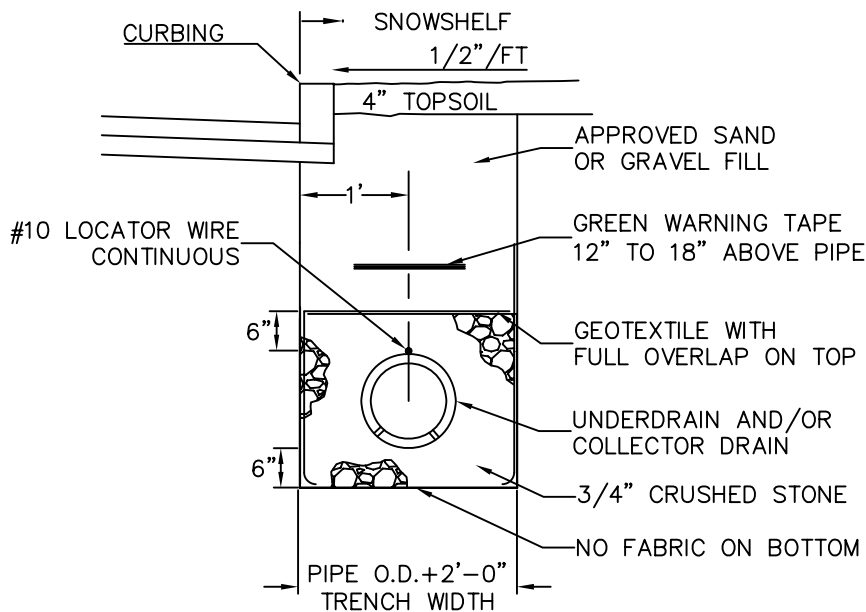

TRENCH DETAIL

NOTES:

1. PERFORATIONS TO BE PLACED DOWN.
2. HOLES ARE TO BE 1/2" DIAMETER OR 5/8" DIAMETER
3. PIPE SHALL BE MIN. 6" DIAMETER (SEE SPECS).
4. SLOTTED REINFORCED CONCRETE PIPE (SRCP) CAN BE USED AS A COMBINED STORM, UNDERDRAIN, AND COLLECTOR DRAIN SYSTEM.
5. ALL UNDERDRAINS TO BE OUTLETTED DIRECTLY INTO A CATCH BASIN. THE TOP OF THE UNDERDRAIN PIPE IS TO MATCH THE TOP OF THE OUTLET PIPE IN CATCH BASIN.
6. NO FLEXIBLE CORRUGATED PLASTIC PIPE IS TO BE USED UNLESS APPROVED BY THE ENGINEER.



TOWN OF WINDSOR
Engineering Department



UNDERDRAIN / COLLECTOR DRAIN
D-301



SCALE: $\frac{\text{HOR. NTS}}{\text{VER.}}$ DATE: MAY 2010