

CODE	DESCRIPTION	SUGGESTED PRODUCT
MAIN	100 AMP 2 POLE 240 VOLT CIRCUIT BREAKER	G.E. #THQL 2100
CONT.	60 AMP 2 POLE 120 VOLE CIRCUIT BREAKER	G.E. #THQL 2100
LC	2 POLE 60 AMP LIGHTING CONTRACTOR	CUTLER-HAMMER #C30 DN2-AB
PC	STEM MOUNT PHOTO CONTROL	PRECISION MULTIPLE CONTROL ST-15
R	20 AMP 125 VOLT GFCI DUPLEX RECEPTACLE	
	INCANDESCENT LAMP HOLDER WITH PULL CHAIN	
LP	100 AMP MAINLUG ONLY, 8-12 CIRCUIT LOAD CENTER	G.E. #TLM 1612C OR APPROVED EQUAL
OR	60 MINUTE TIMER WITH HOLD FEATURE	INTERMATIC #FF60MH

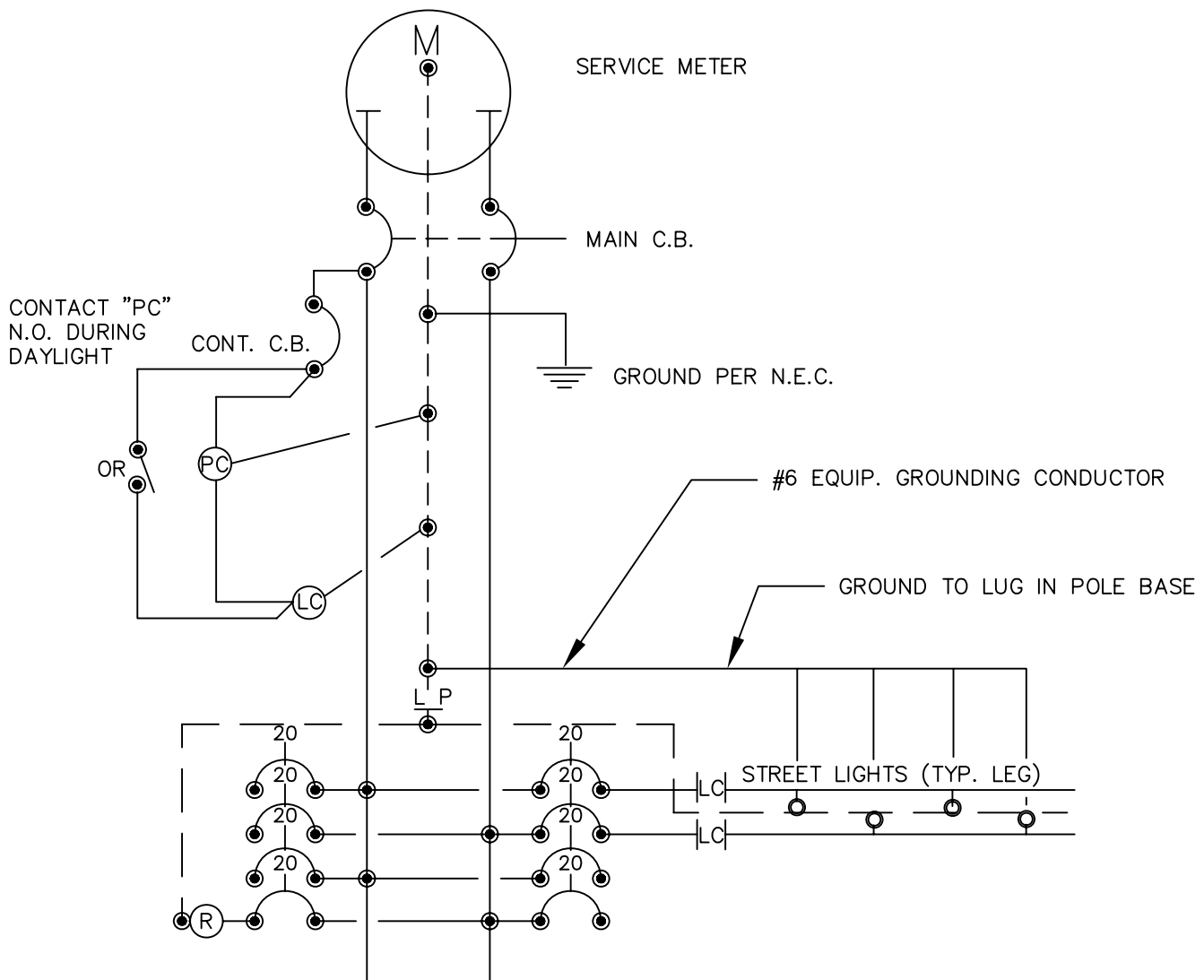

TOWN OF WINDSOR
Engineering Department



STREET LIGHT ELECTRICAL
DIAGRAM-CONTROL PANEL
D-406



SCALE: HOR. NTS
VER. DATE: MAY 2010